

mesytec **MHV-4** is a modern 4-channel high precision bias supply unit for detector bias voltages up to 800 V. It is designed to supply highly stable bias voltage for all types of silicon and gas detectors. The output current is limited to 20 μ A.

The new revision allows easy operation of large area avalanche diodes, by compensating the bias voltage with temperature. Temperature measurement can be performed with miniaturized NTC temperature sensors. The four temperatures are also available via USB or mesytec control bus.

Features:

- Precise voltage setting up to 800V, in steps of 12.5 mV
- lowest noise voltage of < 1 mVrms at 400 V.
- Current display resolution 1 nA
- 4 large and bright LED displays allow simultaneous survey of all currents or voltages
- Full 4 digit display
- Universal 4 channel temperature measurement and HV compensation for avalanche diodes. (external sensors: standard NTCs)
- Adjustable HV ramp speed
- Output connectors: SHV or BNC
- Adjustable current warning threshold and voltage limit for each channel. Acoustical and optical current warning.
- Individual polarity select for each channel at the front panel.
- Remote control: All parameters can be set via USB or mesytec control bus (using an MRC-1 / MRCC master module)



Technical Data:

Power consumption

- +6V, +700 mA
- -6V, -70 mA
- -12V, -50mA
- due to low power consumption no cooling fans necessary

Voltage Output

- Voltage range: 0 ... +/-800 V
- adjustable in steps of 12.5mV
- High quality rotational encoders with dynamic step width
- Typical noise $N < 1 \text{ mV}$ (400 V, 5 Hz to 100 MHz)
- Voltage stability: typ 0.015 %/°C
- Calibration precision: 0.5 %
- Output current max. 20 uA per channel, limited
- Adjustable voltage ramp up and down of 5V/s up to 500V/s
- Ramp up after power failure

Display

- Full 4 digit display
- Current display with 1 nA resolution up to 20.00 uA
- Voltage display:
up to 100V: 0.01(25) V steps
100V to 800 V: 0.1 V steps

Current warning

- Individual warning thresholds adjustable from 1 nA to 20 uA.
- Acoustical and optical warning when threshold is exceeded.

Connectors

- HV outputs: BNC or SHV
- USB remote control: standard USB B
- mesytec control bus: Standard NIM Lemo connector 00 series
- Temperature sensors: 2.54 mm pitch header connector

Temperature measurement

When using temperature sensitive detectors like Si- detectors, which have temperature dependent leakage currents, or Scintillators with temperature dependent light output, it is helpful to monitor the detector temperature to allow later corrections at the analysis of data.

The new revision of MHV-4 allows to monitor up to 4 temperatures with unexpensive standard NTCs, which can be glued to a setup. Measured temperatures can be displayed and read out via USB or mesytec control bus.

The high resistance of the sensors, and low pass filters



in the module, allow to use almost any available cabling like coax or twisted pair cables.

Sensor connector pinout:

Pin	Signal
1, 2	gnd
3, 4	Sensor 0, gnd
5, 6	Sensor 1, gnd
7, 8	Sensor 2, gnd
9, 10	Sensor 3, gnd

- Sensor type: NTC thermistor, Epcos B57861-S502-F40 (5 kOhm @ 25 °C, B = 3988)

Temperature compensation

When Avalanche Photo Diodes with high gain (50...300) are used, (bias voltage around 350 to 600V) the temperature drift of gain has to be taken into account. It will be about 5% /°C. So a temperature compensation via Bias voltage (typ +0.78V / °C) may be necessary.

MHV-4 brings an automatic temperature compensation feature.

If selected, the output voltage of each channel depends on the temperature measured by one of four possible NTC sensors. Reference temperature and correction slope can be set in wide ranges.

- Each HV channel can be assigned freely to one of the sensor channels
- Compensation offset (= temperature resulting in $V_{comp} = 0$ V) can be adjusted between 0°C and 50 °C (32°F and 122°F)
- Compensation slope can be adjusted between -9.99 V/°C and +9.99 V/°C

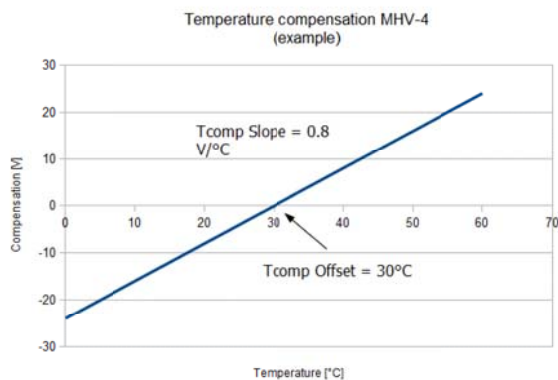

MHV-4 Frontpanel:

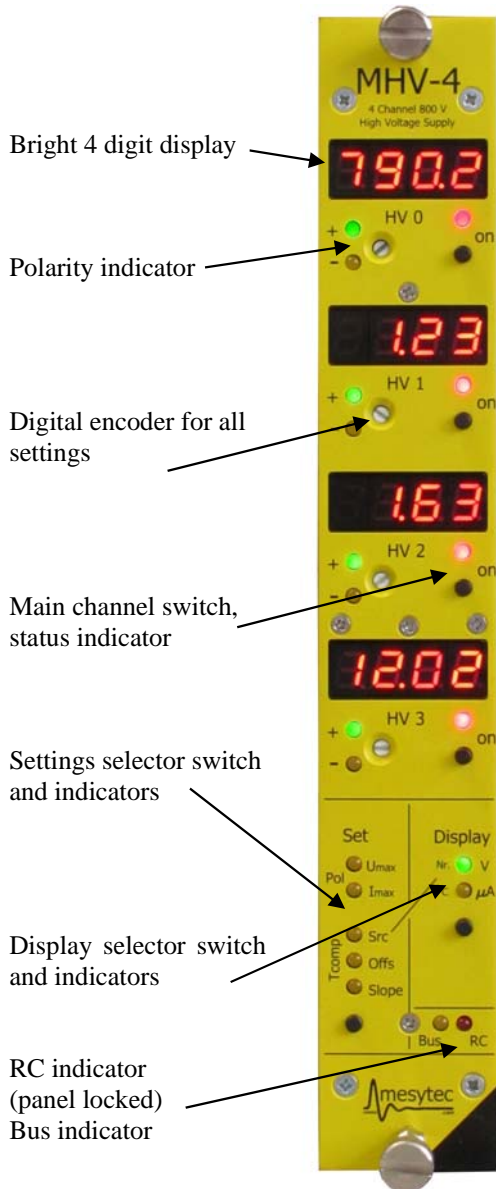

MHV-4 Backpanel:

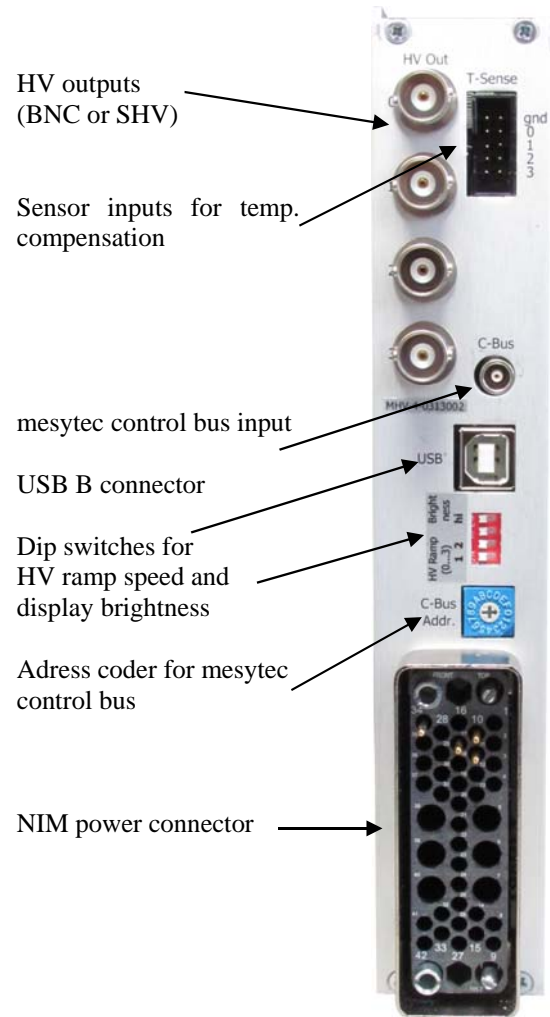

MHV-4 frontpanel operation:

- **On / Off:**

push main channel switch to toggle between on and off status.

On:

HV will be ramped up/down with given HV ramp speed (ramp speed is set by backpanel dip switch or via RC).

Red „on“ indicator will blink during ramping and will light steadily when preset voltage is reached.

Display shows measured voltage at HV output.

Off:

If HV = 0V, red „on“ indicator LED turns off. Display shows preset Voltage instead of measured output voltage.

Press settings selector to reach the different settings:

- **Voltage limit:**

Voltage limit can be adjusted between 0 and 800 V. Voltage preset can not be set higher than voltage limit .

- **Current limit:**

If current limit is exceeded, an acoustical alarm will be emitted, and channel indicator LED will blink.

Max. current can be adjusted between 0 and 20 μ A.

- **Polarity:**

Can be set positive or neagative.

If polarity is changed while HV is on, HV will be ramped down automatically before polarity is changed. The Voltage will be automatically set to 0 V.

- **Temperature compensation:**

MHV-4 allows automatic compensation of HV level according to temperature measured at one of four possible sensor inputs.

Tcomp parameters are accessibe if at least one sensor is connected.

Three parameters are adjustable:

Source :

select input number 0...3 as sensor source for the HV output channel.

HV will then be autmatically compensated according to parameters „offset“ and „slope“.

If „off“, no compensation will be applied to output voltage.

Display can be toggled between source number and measured temperature at this input by clicking the display selector switch.

Offset :

defines the temperature with a compen sation value of 0V (no compensation).

Values between 0 °C and 50 °C are possible.

Slope :

defines the (positive or negative) compensati on slope, applied referring to the offset tempe rature.

Values between -9.99 V/°C and 9.99 V/°C are possible.

A reasonable starting value for typical APDs will be +0.8 V/°C.

Remote control via USB:

- MHV-4 can be remote controlled via USB, e.g. using a standard ASCII terminal program.
- Baud rate: 9.600 Bd
- Data Format: 8N1 (8 bit, no parity, 1 stoppbit),
- input characters are echoed

Commands:

c = channel number 0...3, 4/a = all

Set Commands:

ON c switch channel n on

OFF c switch channel n off

SU c vvvv set voltage of channel n
 vvvv = voltage in 0.1 V
 e.g.: SU 0 4000 sets channel 0 to 400 V

SUL c vvvv set voltage limit of channel n
 vvvv = voltage in 0.1 V
 e.g.: SUL 0 4000 sets voltage limit for channel 0 to 400 V

SIL c iiii set current limit of channel n
 iiii = current in nA
 e.g.: SIL 0 4000 sets current limit channel 0 to 400 V

SP c p set polarity of channel n
 p = polarity: p/+/1 or n/-/0
 e.g.: SP 0 n sets polarity channel 0 to negative
 For security reasons: if HV is on, it will be switched off automatically, HV preset will be set to 0 V, polarity is switched when HV is down.
 After switching: set presets again to desired values.

STC c n: set temperature compensation for channel c
 n = channel number of NTC element (0...3, -/4 = off)
 e.g.: STC 0 0 switches temp comp. for channel 0 on and selects NTC input 0 as source for T information.
 STC 0 - switches temp comp. for channel 0 off.

STO c ttt: set reference temperature for channel c
 ttt = temperature in 0.1°C
 e.g.: STO 0 285 sets reference temperature for channel 0 to 28.5°C

STS c ssss: set temperature compensation slope for channel c to ssss mV/°C
 e.g.: STS 0 800 sets slope for channel 0 to 0.8 V / °C
 positive / negative values allowed
 e.g. STS 0 -1200 for -1.2V / °C

SRA n set HV ramp speed
 n = 0: 5 V/s, 1: 25 V/s,
 2: 100 V/2, 3: 500 V/s

Read Commands:

RU c read voltage channel c

RUP c read voltage preset channel c

RUL c read voltage limit channel c

RI c read current channel c

RIL c read current limit channel c

RP c read polarity channel c

RTC c read complete settings for temp compensation channel c

RT c read temperature at input c

RRA read HV ramp speed

Remote Control via mesytec serial event bus (MRC-1 / MRCC master controller needed)

As an option, MHV-4 can also be remotely controlled via mesytec control bus using the rc master modules MRC-1 or MRCC.

This enables setting up larger systems, also combining different modules (such as MHV-4 and the 16 channel shapers STM-16 / MSCF-16 or the neutron/gamma discriminator MPD-4 / MPD-8), all being accessed from one command interface. The setup data for all connected modules can be stored in the MRC-1 / MRCC. After power up or when the reset pushbutton is pressed, it automatically reinitializes all devices with the stored values.

Memory layout:

All MHV-4 parameters that are accessible by remote control are represented in a memory page that can be read and/or written by MRC-1 / MRCC commands.

Write registers contain setup/preset values and can be written/read.

The corresponding read (only) registers represent the measured values. They may differ from the preset values (e.g. when a channel voltage is preset, but the channel is switched off).

Layout of the memory page is described on the following pages.

Read/Write access:

Memory positions are written with the SE (= set) command and read with the RE (= read) command. (please see command listing below for detailed cmd information)

Mirror page:

For very safe operation a mirror page is available. It is a second write memory page that can be written without triggering changes in the current MHV-4 setup. Write and read commands are SM (= set mirror value) and RM (= read mirror value). When everything is written and confirmed, values can be all together copied to the active page with CP (= copy mirror page), where they take effect immediately.

The ON / OFF commands lock / unlock the MHV-4 front panel. Lock status is saved immediately and restored on power up.

Identification code for MHV-4 (detected when running the scan bus command "SC") is IDC = 17

MRC-1 / MRCC command Summary:

cmd format:

cmd bus [dev] [adr] [val]

bus = bus number [0...1]
dev = device number [0...15]
adr = parameter number [0...31]
val = See memory list page 4

SC bus

Scans given bus (0, 1) and returns id code (IDC) for each device number that responds. MHV-4 will return IDC=17.

ON bus dev

Activates remote control for given device @ bus. Will invoke rc settings instead of panel settings. (Be sure to have parameters set correctly or in a sure range before activating rc.)

OFF bus dev

Switches off remote control for given device @ bus. Returns settings to panel values.

SE bus dev adr val

Set direct memory address adr in device @ bus to value val. Changes will take effect immediately if rc is switched on. For a special safe setup and common application of all set values, please use the mirror memory and copy command.

RE bus dev adr

Read value from direct memory address adr in device @ bus.

SM bus dev adr val

Same as SE command, but writes to the mirror memory page. Values are copied to direct memory using the CP copy command. Presets can be changed safely and will only take effect if copied to direct memory.

RM bus dev adr

Read mirror memory – returns the preset value out of mirror memory.

CP bus dev

Copy mirror memory to active memory. Presets will take effect immediately if rc is switched on.

Value	Write Address	Read Address	Comment
- Write addresses can be read and written. - Read on write addresses delivers written value (possibly corrected by boundary check). - Read addresses are „read only“ and deliver current hardware status which might deviate from written value. (due to on/off switches, set limits, transient status, compensation, ...)			
Voltage 0	0	32	Set / read channel voltage
Voltage 1	1	33	Write: 0... 8000 = 0 ... 800.0 V Read: 0 ... (-)8000 = 0 ... (-) 800.0 V (also indicating polarity)
Voltage 2	2	34	
Voltage 3	3	35	
On/Off 0	4	36	Set / read channel switch status
On/Off 1	5	37	Read / Write: 0 = off, 1 = on
On/Off 2	6	38	
On/Off 3	7	39	
Cur. Lim. 0	8	40	Set / read current limit
Cur. Lim. 1	9	41	Read / Write: 0 ... 20.000 = 0 ... 20.000 nA (0 ... 20 uA)
Cur. Lim. 2	10	42	
Cur. Lim. 3	11	43	
RC on/off (Panel Lock)	-	44	Set by „ON b a“ command, read: 0 = off, 1 = on
Polarity 0	14	46	Set / read channel polarity
Polarity 1	15	47	Read / Write: 0 = negative, 1 = positive Switching polarity automatically includes: channel switched off, voltage preset = 0 for security reasons. Switching may take time depending on HV ramp speed.
Polarity 2	16	48	
Polarity 3	17	49	
Current 0	-	50	Read channel current
Current 1	-	51	Read: 0 ... (-)20.000 nA
Current 2	-	52	
Current 3	-	53	
Volt. Lim. 0	18	22	Set / read channel voltage limit
Volt. Lim. 1	19	23	Read / Write: 0... 8000 = 0 ... 800.0 V (no polarity)
Volt. Lim. 2	20	24	
Volt. Lim. 3	21	25	
Temperature 0	-	26	Read temperature at sensor (if connected)
Temperature 1	-	27	Read: 0 ... 500 = 0 ... 50.0 °C (999 if no sensor connected)
Temperature 2	-	28	
Temperature 3	-	29	
T Comp. Slope 0	64	100	Read / set slope for temperature compensation
T Comp. Slope 1	65	101	Read / write: 0 ... 19.999 = - 9.999 V/°C ... +9.999 V/°C (10.000 = 0 V/°C)
T Comp. Slope 2	66	102	

Value	Write Address	Read Address	Comment
T Comp. Slope 3	67	103	
T Comp. Offs. 0	68	104	Read / set offset (= Temperature with compensation = 0.0 V) for temperature compensation Read / write: 0 ... 500 = 0.0 °C ... 50.0 °C
T Comp. Offs. 1	69	105	
T Comp. Offs. 2	70	106	
T Comp. Offs. 3	71	107	
T Comp. Src. 0	72	108	Read / set sensor input for temperature compensation. Read / write: 0...3 = input #, 4 = off
T Comp. Src. 1	73	109	
T Comp. Src. 2	74	110	
T Comp. Src. 3	75	111	
HV prec. 0	76	112	Read / set voltage in binary units, 1 = 12.5 mV Read / write: 0 ... 64.000 = 0.0 ... 800.0 V
HV prec. 1	77	113	
HV prec. 2	78	114	
HV prec. 3	79	115	
Ramp Speed	80	116	Read / set HV ramp speed Read / write: 0 ... 3 0 = 5 V/s, 1 = 25 V/s, 2 = 100 V/s, 3 = 500 V/s